



OxyFlow 5

OXYGEN CONCENTRATOR SERVICE MANUAL



Sanrai International
1701 North St Suite 40-2,
Endicott, NY 13760
United States

TABLE OF CONTENTS

PART I General Safety Notice	1
Special Notes	
Safety Summary	
1.1 Use of oxygen	
1.2 Use and maintenance of the device	
PART II General Introduction.....	2
2.1 Distributor/dealer responsibility	
2.2 Important notice and symbol explanations	
2.3 Specifications	
Part III Working Principle.....	5
3.1 Working principle	
Part IV User Instructions.....	5
4.1 General instructions	
4.2 Routine maintenance by the user	
4.2.1 Cleaning the air inlet filter	
4.2.2 Cleaning nasal tube and humidifier bottle	
Part V Distributor/dealer Maintenance.....	6
5.1 Routine maintenance	
5.1.1 Cabinet air inlet filter	
5.1.2 Inlet filter replacement	
5.1.3 Bacteria filter replacement	
5.1.4 Taking record	
5.2 Preparing for new user	
Part VI Repair/replacement Guide.....	8
6.1 Outside, inside structure	
Outside structure	
Inside structure	
Circuit board layout	
6.2 Cabinet removal	
6.2.1 Removal cabinet front and back	
6.2.2 Caster replacement	
6.3 Compressor	
6.3.1 Compressor replacement	
6.3.2 Compressor start capacitor replacement	
6.4 Pneumatic valve replacement	

- 6.5 Pressure equalizing valve replacement
- 6.6 Sieve beds replacement
- 6.7 Fan replacement
- 6.8 Circuit board replacement
- 6.9 LCD replacement
- 6.10 Pressure regulating valve replacement
- 6.11 Power switch replacement
- 6.12 Flow meter replacement

Part VII Trouble Shooting Guide..... 22

- 7.1 General trouble shooting
- 7.2 Trouble shooting table
- 7.3 Tools table
- Attachment -Circuit Diagram

PART I General Safety Notice

SPECIAL NOTES

- The procedures in this manual must be performed by the supplier, dealer or an appointed maintenance company only.
- Please read this service manual closely. DO NOT use this product or any available optional equipment without first completely reading and understanding these instructions and any additional instructional material such as other documents supplied with this product or optional equipment, otherwise, injury or damage may occur.
- If you are unable to understand the warnings, cautions, or instructions, contact your supplier before attempting to use this equipment.
- Keep this manual for future reference.
- Do not use unauthorized parts or accessories other than those authorized by Sanrai International.

NOTICE: THE INFORMATION CONTAINED IN THIS DOCUMENT IS SUBJECT TO CHANGE WITHOUT NOTICE

SAFETY SUMMARY

1.1 Use of oxygen

- The machine must be kept far away from fire and heat. DO NOT SMOKE while using this device for your own safety. Keep all matches, lighted cigarettes, or other sources of ignition out of the room.
- Keep power cord away from sources of ignition and heat.
- Turn off the power when not in use.
- DO NOT put the oxygen tubing under bedspreads or chair cushions.
- Unplug the power cord when cleaning or servicing the device.
- DO NOT use any lubricants unless recommended by Sanrai International.
- Keep the unit in a dry, well-ventilated room, without dust, corrosion, and toxic gases. Keep the unit away from sunlight and electromagnetic interference.

1.2 Use and maintenance of the device

- This equipment is not to be used for life support.
- Use of the unit must be restricted solely to oxygen therapy with a medical prescription in compliance with the flow and period set by the physician.
- Do not use in a magnetic environment (MRI, etc.).
- The concentrator has an audible alarm intended to warn the user of any problems. The user must determine the maximum distance away from the unit, based on the sound levels in the environment, to ensure that the alarm is always audible.
- The Operating Environment Temperature of this concentrator is 10-37°C, if lower than 10°C, the compressor may be difficult to start; if higher than 37°C, the compressor may overheat.
- NEVER block the air inlet of the concentrator or place it on a soft surface, such as a bed or couch, where the air exhaust outlet may be blocked. Keep the openings free from lint, hair, etc.
- Use distilled water or cold boiled water in the humidifier.
- Keep the water level below the maximum fill line on the humidifier
- For optimum performance, Sanrai International recommends that each concentrator be on and running for a minimum of 30 minutes at a time. Shorter periods of operation may reduce maximum product life.
- Response Time: Acceptable purity is normally achieved in about 240 seconds, allow 6 minutes to attain complete purity.
- Do NOT turn the flow ball in the flow meter up to the red line or the purity of oxygen will decrease.
- DO NOT come in contact with the concentrator while wet.
- Operate the unit in an upright position, maintaining at least twelve inches of open space on all sides for ventilation.
- Do not operate the machine for more than 15 minutes without the cabinet closed.

Do not open the device when it is powered on: risk of electrocution.

This device complies with the requirements of the EU Directive 93/42/EEC, but its operation may be affected by the use in the surrounding area of appliances such as diathermy, high frequency electro-surgical instruments, short wave treatment appliances, cell-phones, microwave ovens, induction hot plates or remote control toys, and more generally, by electromagnetic interference exceeding the levels specified in standard IEC(EN) 60601-1-2.

PART II General Introduction

2.1 Distributor/dealer responsibility

All Distributors/dealers of the Sanrai International OxyFlow 5 Series Oxygen Concentrator must assume responsibilities for handling, operational check-out, user instruction, and maintenance. These responsibilities are outlined below and throughout this manual.

 **WARNING** Sanrai International units must not be used for or with any life-supporting or life sustaining applications. Patients unable to communicate discomfort while using this device may require additional monitoring. Advise patients to immediately notify their physician(s) and/or dealer in case of an alarm or any discomfort.













As a Distributor/dealer, please perform the following steps:

- Inspect the condition of each OxyFlow 5 unit immediately upon delivery to your business location. Take note of any signs of damage, external or internal, on the delivery and report it directly to both the freight company and Sanrai International immediately.
- Check the operation of each concentrator before delivery to a patient. Always operate the unit for a reasonable length of time and check that the oxygen concentration level is within the specifications. Test the power failure alarm.
- This equipment is not to be used for life support and is only to be used as an oxygen supplement. Other backup oxygen supply devices for the patients who are in dire need of oxygen must be available. (Such as an oxygen cylinder or liquid oxygen)
- Instruct patients on how to use the concentrator in conjunction with the User Manual.
- Instruct each patient how to perform routine maintenance of the air filter, nasal tube and humidifier bottle. (Refer to Part IV 4.2) Be available to service each patient at any time. Maintain the concentrator in accordance with Part V and Part VI.
- Repair components and replace parts only as outlined in this manual. Use only Sanrai International parts for replacement in OxyFlow 5 Oxygen Concentrators.

2.2 Important Notice and Symbol Explanations

As you read the manual, pay special attention to the WARNING, CAUTION, and NOTE messages. They identify safety guidelines or other important information.

IEC SYMBOLS

	ON
○	OFF
	Consult the manual
	No Smoking
	Warning & Caution! Consult the manual
	Type BF Equipment
	European CE Declaration of Conformity
	Alternating Current
	Stacking Level Limit
	Upright
	Frangibility
	Do not wet
	Temperature Limit
	Class II (Double Insulated)
	Our medical product is labeled with this symbol in accordance with European Directive 2002/96/EG (Waste Electrical and Electronic Equipment - WEEE) to indicate that, at the end of its life, it must be disposed separately from other household waste. Please contact your local authority or waste disposal service for the return and recycling of this product.

2.3 Specifications

Machine performance and parameters

Parameters	rating		regulating		Sound level (dB (A))	Functions
	Flow (L/min)	Purity (%)	Flow (L/min)	Purity (%)		
OXYFLOW 5	5	93±3%	1-5	93±3%	≤45	Standard Function: Temperature alarm, low oxygen concentration alarm, power failure alarm, maintenance reminder Optional Function: Positive pressure outlet

Parameter configuration form

Model no.	OXYFLOW 5
Rating power (W)	300
Rating current (A)	1.5
Electrical Requirement	220V±10%, 50Hz±1Hz
Flow rate (L/min)	1-5
Purity (5L/min)	93±3%
Outlet pressure (psi)	7.345 ± 10%
Sound level dB(A)	≤45
Net weight (kg)	14.2kg
Dimension (mm)	390×230×600
Equipment class and type	Class IIa

Notice: The information contained in this manual is subject to change without notice.

Part III Working Principle and Routine Checking Operations

3.1 Working principle

Oxygen Concentrators use pressure swing adsorption technology. At normal temperature, the machine will continuously separate oxygen from the air.

Note: Using an oxygen concentrator does not influence the oxygen content in the air of the room.

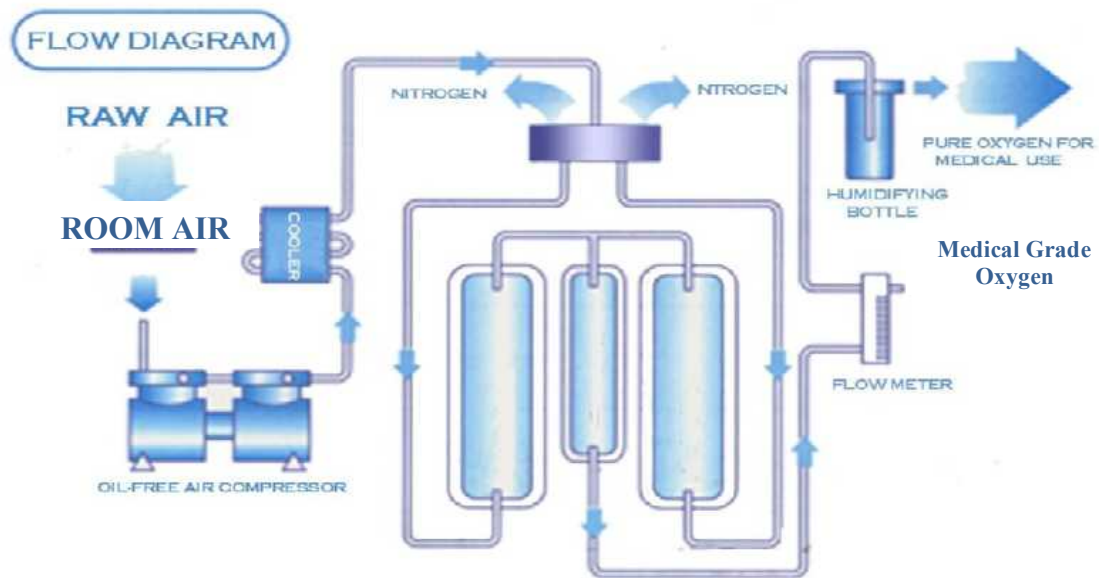

Part IV User Instructions

4.1 General instructions

It is important that patients thoroughly understand how to operate the Sanrai International oxygen concentrator unit. This enables proper treatment as prescribed by a qualified, licensed physician. The dealer should explain that the purpose of this therapy is to alleviate symptoms. If patients experience any discomfort or the unit alarms, they must notify their Home Care Service Provider and/or physician immediately. The Dealer is responsible to see that each patient receives the Patient Manual. The Dealer should explain each step in the operation of the unit to the patient in reference to this manual.

4.2 Routine maintenance by the user

To ensure accurate output and efficient operation of the unit, the patient must perform two simple routine maintenance tasks:

- Cleaning the cabinet air inlet filter
- Cleaning nasal tube and humidifier bottle

4.2.1 Cleaning the cabinet air inlet filter

- When the machine is turned off, clean the outside case with a soft wet towel with some detergent. Then wipe it with dry towel, once or twice per month.
- The air intake filter is used to prevent dust, and needs to be cleaned regularly. It is a critical step for ordinary maintenance to clean the filter, at least once a week depending on environmental conditions. This filter may require daily cleaning if the unit operates in a harsh environment.

Operation steps as below:

- A. Take off the filter nets at the rear of the cabinet and take out take out the filter (mesh sponge).
- B. Rinse the filter (mesh sponge) with clean water. Get rid of the extra water and dry completely.
- C. Replace after it's dry
- D. Use the backup filter while the original filter is being cleaned



NOTE: If a replacement is needed, please use the same Sanrai International accessories. Do not operate the unit without the air intake filter in place.

4.2.2 Cleaning the nasal tube and humidifier bottle

- Clean the cannula every day. First clean it with detergent and then rinse it with clean water and air dry completely. Changing a new cannula once a month is recommended.
- The distilled water or cold boiled water in the humidifier should be refreshed every day.
- The humidifier bottle should be cleaned and disinfected twice a week. Clean the humidifier bottle with detergent and then rinse with warm or hot water. Dip it in a household disinfectant for 20-30 minutes, clean it again with warm or hot water, and then air dry. If it's not in use, please store in a clean bag

Part V Distributor/Dealer Maintenance

5.1 Routine maintenance

The unit has three filters that require scheduled maintenance and replacement. To ensure that the output of oxygen from the unit is accurate, you must perform an oxygen purity test. Test the unit upon delivery to a patient and at periodic intervals. A dealer, based on their expertise and documentation, may establish and implement their own practices for checking oxygen purity. The interval established may be longer or shorter than 180 days, which is the default period recommended for providers who do not choose to establish their own method.

Sanrai International does not require preventive maintenance on the concentrator. You do not need to perform any maintenance if the unit remains within the specifications at the prescribed flow rate.

5.1.1 Cabinet air inlet filter

The external cabinet air inlet filter is located on the rear of the cabinet and is easily removed by hand. Instruct the patient to clean this filter weekly. (Refer to Part IV 4.2.1)

5.1.2 Inlet filter replacement

The inlet filter requires changing every 6 months or 4,000 hours of use.

- (1) Turn off the power, and unplug the power cord.
- (2) Remove the filter access panel to remove and take out the inlet filter.
- (3) Replace with a new filter.
- (4) Reinstall the access panel.



5.1.3 Bacteria filter replacement

The bacteria filter must be replaced after every 5 years or as needed

(1) Turn off the power, and unplug the power cord.

(2) Remove the back cabinet to locate the bacteria filter.

NOTE: Observe the position of the filter before removal.

(3) Separate the silicone tubing from both sides of the filter.

(4) Install the new filter with the inlet side in the same position as before.

(5) Reinstall the cabinet back.

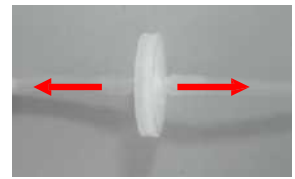

5.1.4 Taking record

As the dealer, it is suggested that you record all routine maintenance and repairs performed on the unit, including hours and dates of service.

5.2 Preparing for new user

With the growing concern about possible cross infection from home oxygen equipment from one home care patient to another, appropriate cautions should be exercised.

When you remove the unit from a patient's home, always dispose of the used nasal cannula and humidifier bottle. Clean the exterior of the unit with a soapy water solution or commercial detergent cleaner to remove any debris, organic or otherwise. Be careful not to get any liquid into the interior of the unit. Next, clean the exterior with a common chemical disinfectant and allow it to air dry. Retest the unit before you return it to your inventory.

Replace the cabinet air inlet filter between each patient, or clean with warm soapy water if it is in good condition. Clean this filter at least once per week or more frequently if operated in a dusty environment. Change the bacteria filter every 5 years or as needed (under adverse conditions, filter may need to be changed more frequently if dingy or dirty) .

Part VI Repair/Replacement Guide

The design of the OxyFlow 5 allows for easy access and removal of most components. This allows you to perform scheduled maintenance, repair, and replacement of parts with minimal time and effort. The OxyFlow 5 has intelligent fault diagnosis, displays malfunction codes, and alarm data on the LCD screen.

6.1 Exterior and Interior structure

Exterior structure

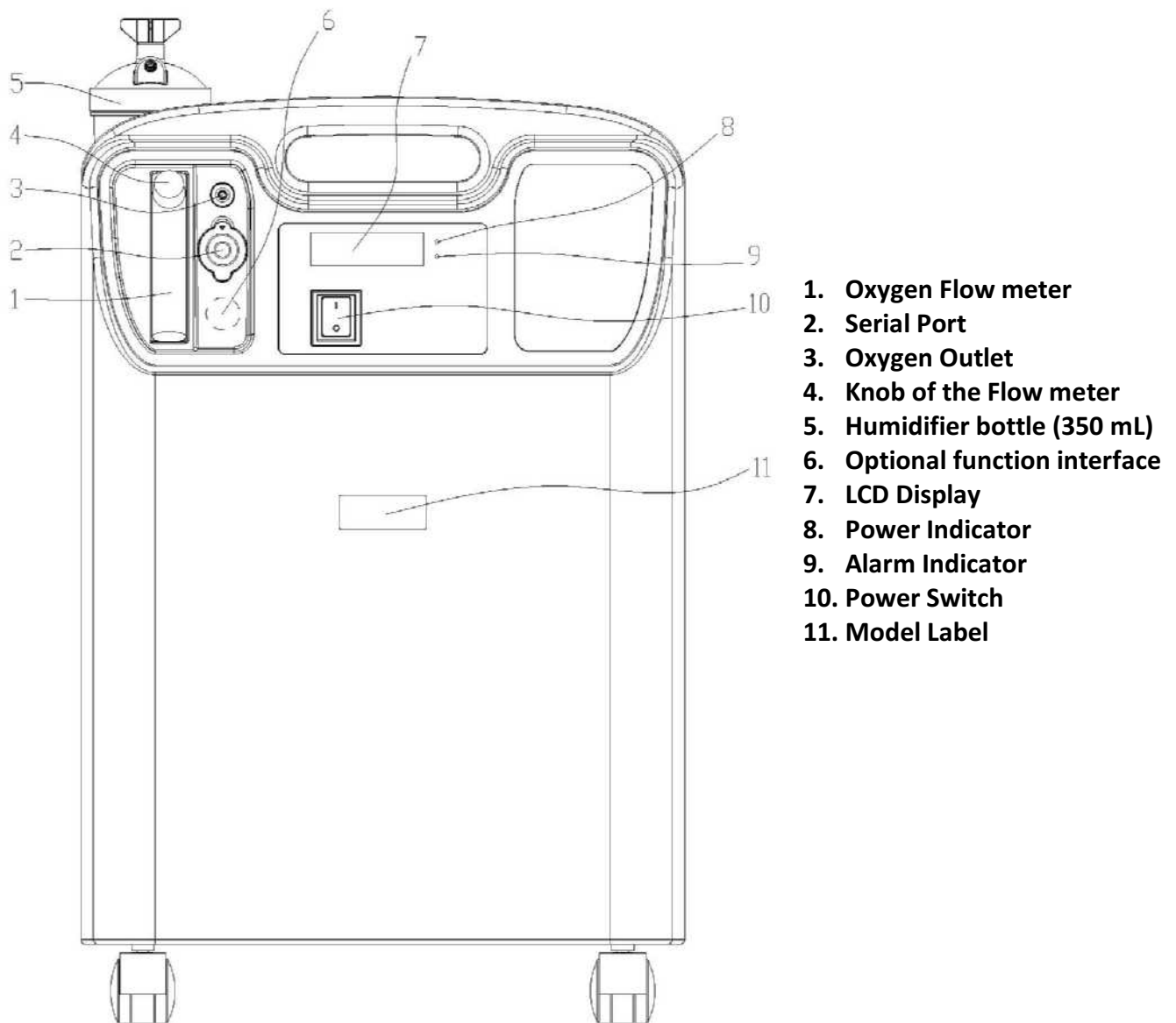

Machine Plan (Front)

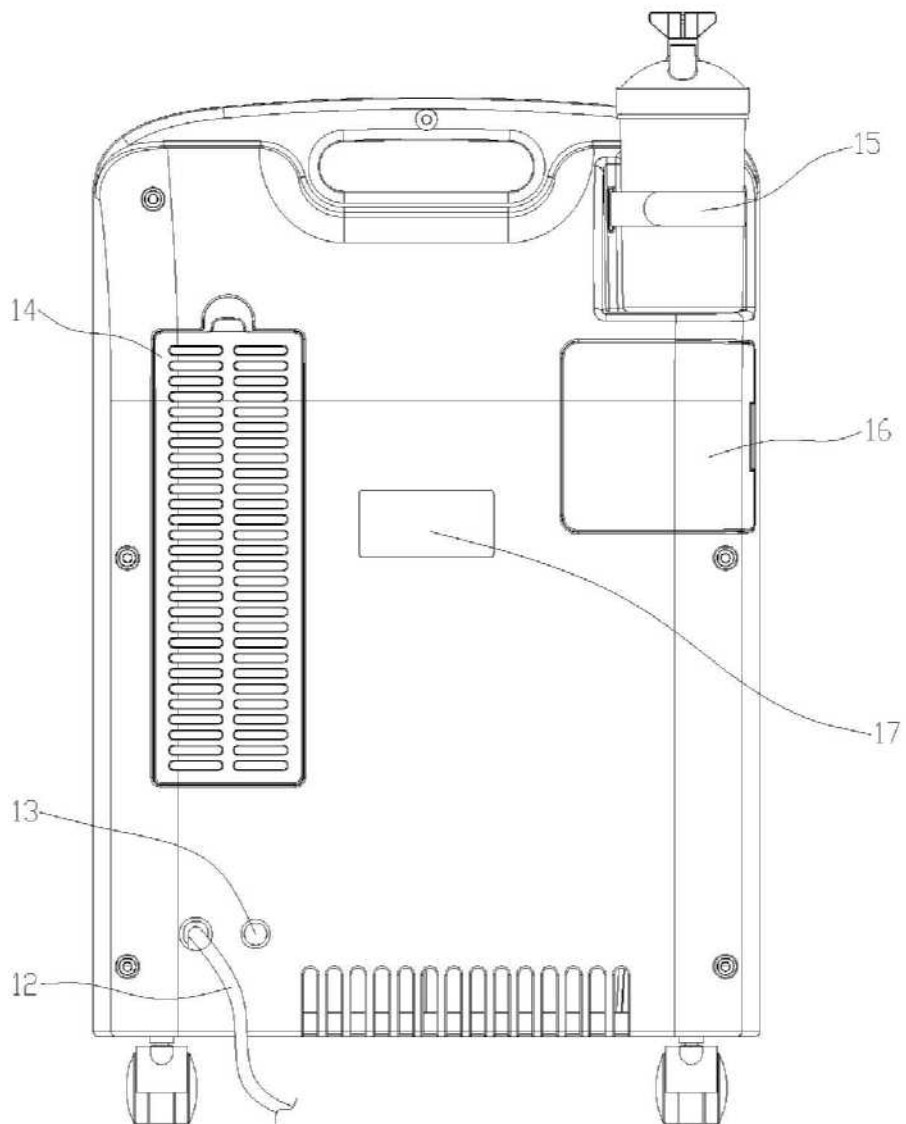

Machine Plan (Back)

- 12. Power Code**
- 13. Over-current protector (Repositor)**
- 14. Cabinet air intake filters**
- 15. Humidifier Band**
- 16. Cabinet filter access panel**
- 17. Specification Label**
- 18. Caster**

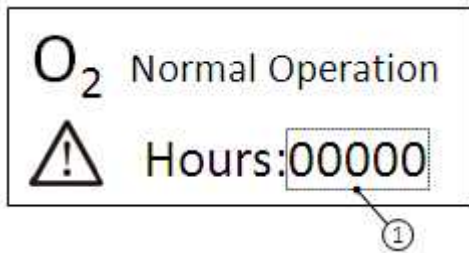

LCD display 1

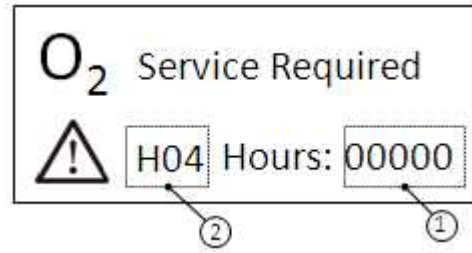

LCD display 2

Content illustration of LCD display:

LCD display 1: Startup display interface indicates the elapsed time of the machine.

LCD display 2: Working display interface with an alarm code.

Zone	Display	Meaning	Status
①	"00000"	Total Running Time (hour)	-----
②	H04	Oxygen concentration is lower than 82%	The red light will flash with an audible alarm
③	H01	Temperature Alarm	The red light will flash with an audible alarm

Note: If multiple alarm codes are generated at the same time, the alarm codes will alternate in the display.

Interior structure

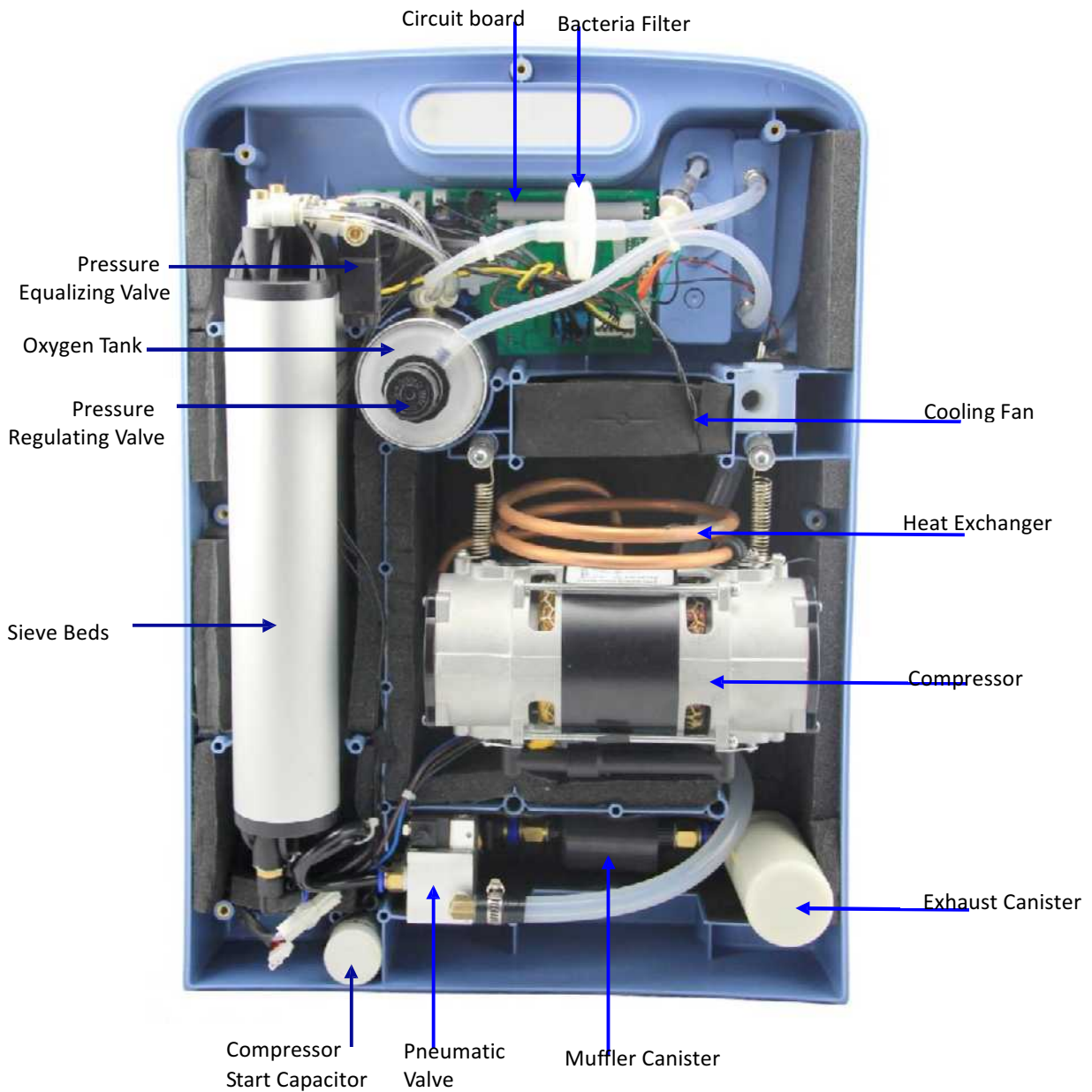

OXYFLOW 5 Circuit board

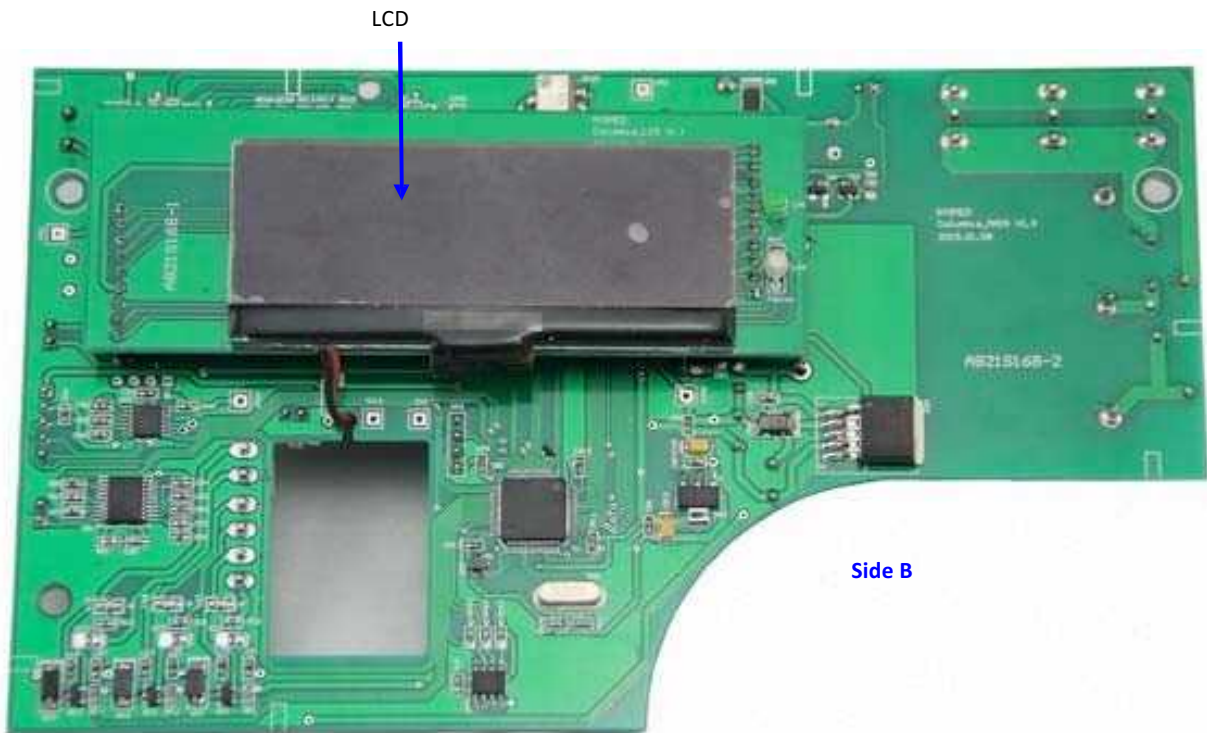
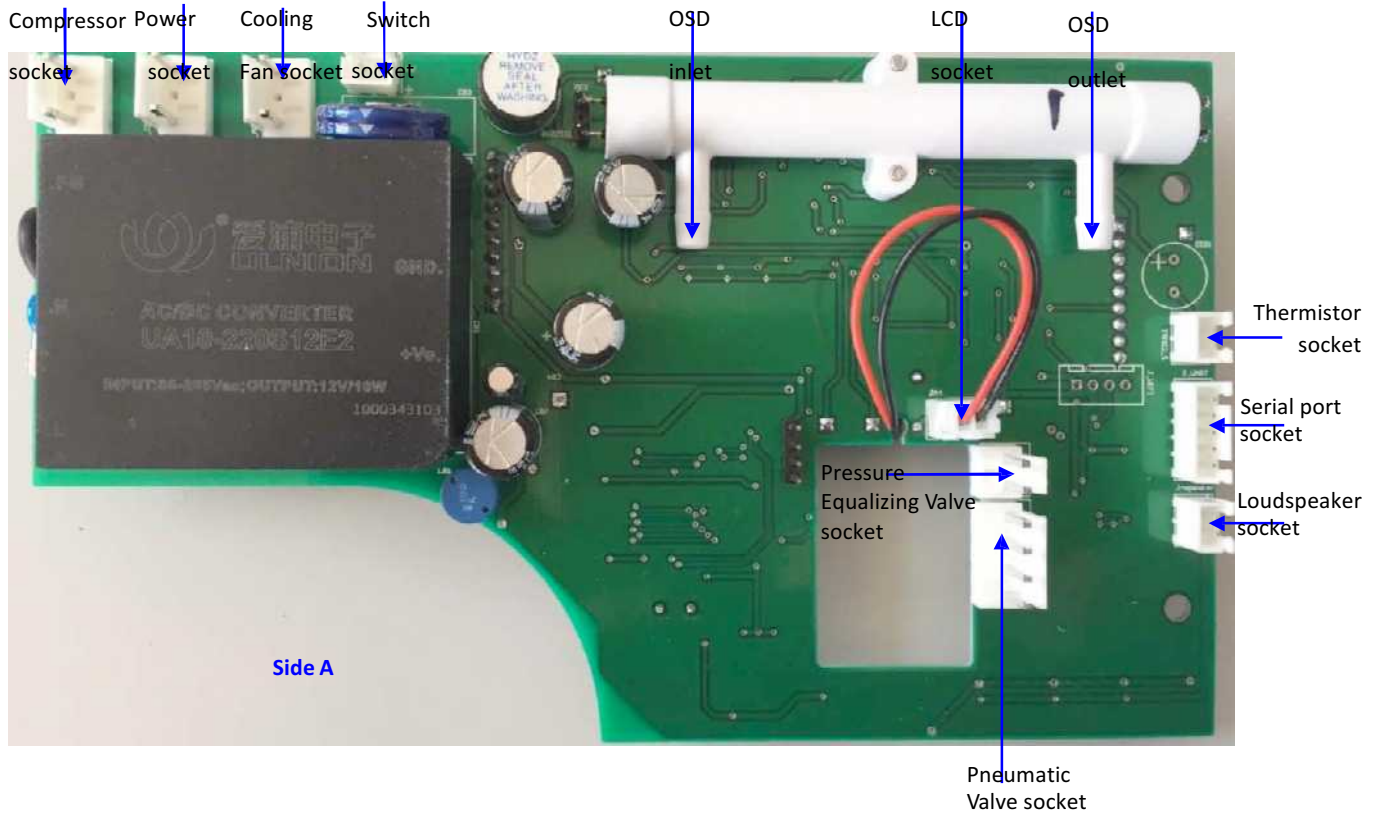

CAUTION: For your safety, be sure to turn off the power and unplug the power cord before you service the Oxygen Concentrator

NOTE: Record all scheduled maintenance.

6.2 Cabinet removal

6.2.1 Remove cabinet front and back

To remove the cabinet front and back, remove seven screws that are on the back of the cabinet. Lift to disconnect the back and front cabinet. Put the back cabinet aside and disconnect the power cord connector to separate the back and front cabinets. See Fig. 6.1 and 6.2



Fig.6.1

NOTE: Pay attention to the force used in the dismantling or assembling process to not break the linked section.

6.2.2 Caster replacement

The casters are a push in type and do not require any fasteners. Lay down the device on its front to access the casters from the bottom. Pull them straight out away from the bottom and then insert new ones.

6.3 Compressor

The compressor is the pump within the oxygen concentrator that supplies air to the sieve beds, and forces oxygen to flow out of the top of the oxygen tank.

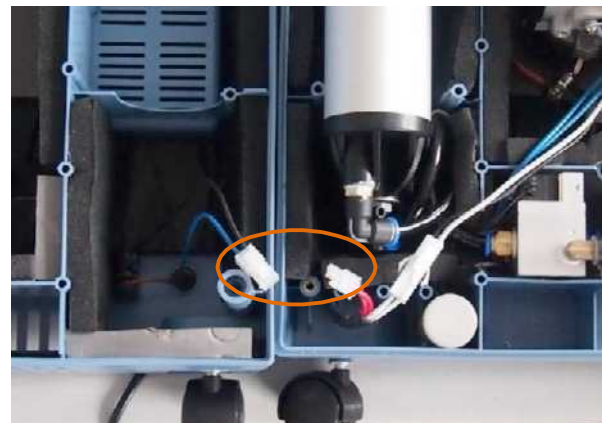
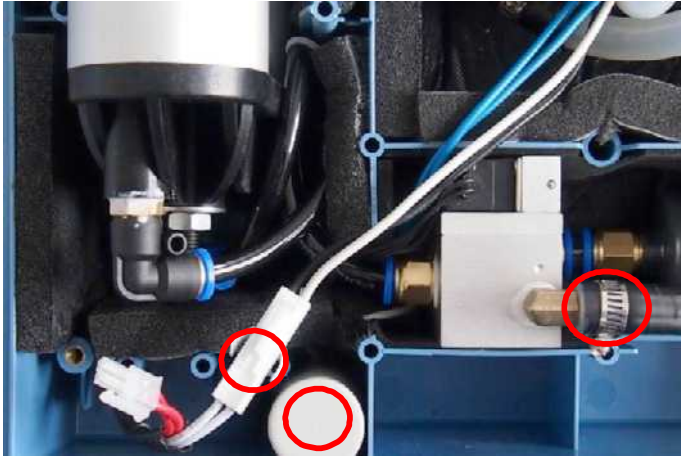

Fig.6.2

6.3.1. Compressor Replacement



To remove the compressor assembly for replacement, follow the steps listed below:

(1) Turn off the power, and unplug the power cord.

(2) Remove the back cabinet.

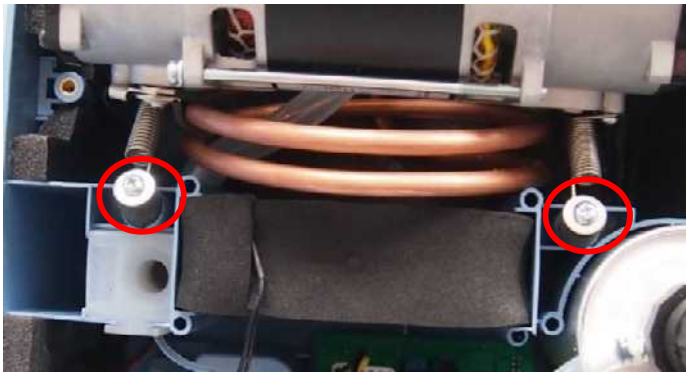

(3) Disconnect the connector of the compressor power wires and take out the compressor start capacitor.

(4) Unscrew the clamp which fixed the compressor tube and pneumatic valve, and pull out the tube.



(5) Remove the screw which fixed the compressor springs and the cabinet.

(6) Remove the screw which fix the thermistor wires, and take off the wires.

(7) Pull out the inlet tube. And take out the compressor.





(8) Unscrew the heat exchange, remove the compressor springs, unscrew the R shape clamp of the exchange.

(9) Take away heat exchange and springs.



(10) Snip the capacitor wire.



To install a new or rebuilt compressor assembly: Perform the compressor removal procedure in reverse order.

Perform leak tests in all connection points

Note: Before installing the heat exchange and spring fittings, add some 704 glue or a significant amount of Teflon tape into the screw hole. Use a cable tie to tighten the inlet tube.

6.3.2 Compressor start capacitor replacement

The capacitor helps the compressor to start and run more efficiently. If the compressor cannot start, the capacitor may be defective and require replacement. To replace the capacitor, perform the following steps:

- (1) Turn off the power, and unplug the power cord
- (2) Remove the back cabinet
- (3) Take out the capacitor from its cavity. Cut the two leads to the capacitor
- (4) Connect the leads to a new capacitor and protect with line cap. Put the capacitor back to the cavity

6.4 Pneumatic valve replacement

The OxyFlow 5 machine uses a pneumatic valve assembly to control the air separation process. The pneumatic valve of the OxyFlow 5 unit requires no scheduled maintenance.

Always check if the sieve beds are working after you replace a valve.

To replace the pneumatic valve, perform the following steps:

- (1) Turn off the power, and unplug the power cord
- (2) Remove the back cabinet
- (3) Disconnect the pneumatic valve wire connector on the circuit board and lift out valve from the cavity
- (4) Disconnect one side of the tube with sieve bed by pushing the blue washer and pull off the tube, and disconnect the other tube in the same way (Note: You may turn the valve to a proper position to take off the tube)
- (5) Unscrew the clamp which fixed the compressor tube and pneumatic valve, and pull out the tube.
- (6) Disconnect tube with muffler canister by pushing the blue washer and pull off the tube
- (7) Replace a new valve and perform the valve removal procedure in reverse order to install

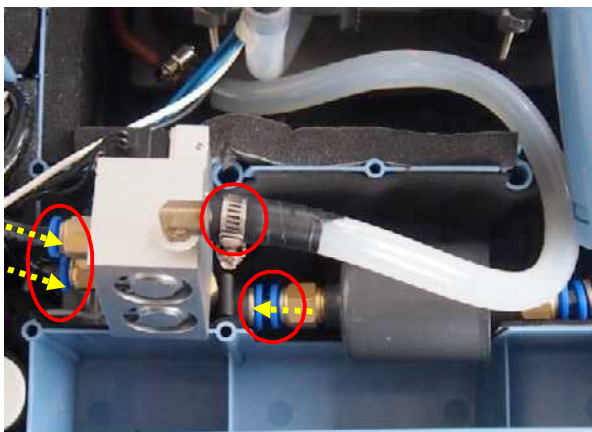

6.5 Pressure equalizing valve replacement

To remove the pressure equalizing valve assembly for replacement, follow the steps listed below:

- (1) Turn off the power, and unplug the power cord
- (2) Remove the back cabinet
- (3) Push the white washer as the yellow arrows indicate in the Fig, and pull out the tube. And take off the tube at the other side of the equalizing valve in the same way
- (4) Disconnect the wire of the equalizing valve which inserts in the circuit board
- (5) Replace a new equalizing valve and perform the valve removal procedure in reverse order to install

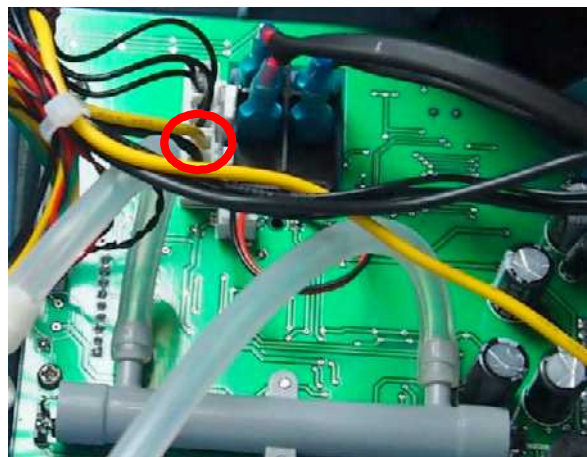

6.6 Sieve beds replacement

The sieve beds are the part of the concentrator that removes nitrogen from the air and allows you to get medical grade oxygen. Over time, the sieve beds can become saturated and might require replacement. This will be indicated by an alarm message from the concentrator.

CAUTION: Do not expose molecular sieve (contents of bed) to air for an extended period. Prolonged exposure of molecular sieve to the moisture in room air results in contamination and permanent damage to the sieve material. Keep all openings to the sieve beds **sealed** during periods of storage.

6.6.1 Sieve Beds Removal

- (1) Turn off the power and unplug the power cord.
- (2) Remove the back cabinet. Refer to removal method of equalizing valve, pull out the tube from the joint of the sieve bed in the same way.
- (3) Pull out the tube which connects with pneumatic valve near the bottom of the sieve bed and take out the sieve beds.

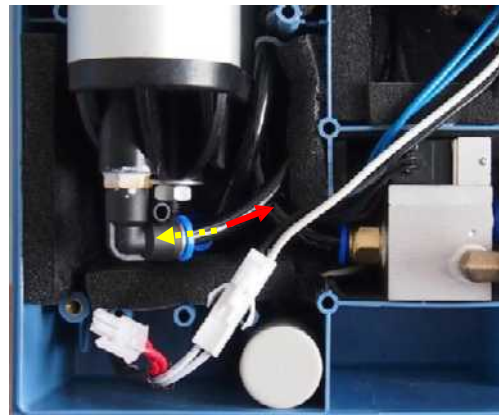
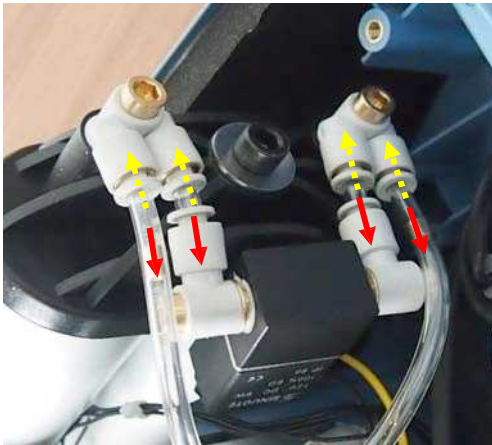

6.6.2 Sieve Beds installation

To install the sieve beds, follow the sieve beds removal procedure in reverse order. It is very important to properly connect all tubes to eliminate leaks.

To check for leaks, take the following steps.

- (1) Plug in the unit.
- (2) Turn on the power switch for three minutes with the flow meter closed to pressurize the system.
- (3) Apply soapy water around every hose connections at the valve and check for leaks.

CAUTION: There is an electrical shock hazard with the Power On. Be careful that no water contacts any of the electrical connections or components.

NOTE: Small leaks can affect a concentrator's performance and can cause contamination of the sieve. Careful leak testing is important.

6.7 Fan replacement

Disconnect the wire connector of the Fan on the circuit board. Take out the fan from the cavity.

NOTE: There is cotton glued the frame of the fan. The wire is on the fan's top. The side with label should be put inside, aligned at the hole, and the wind should blow towards the compressor.

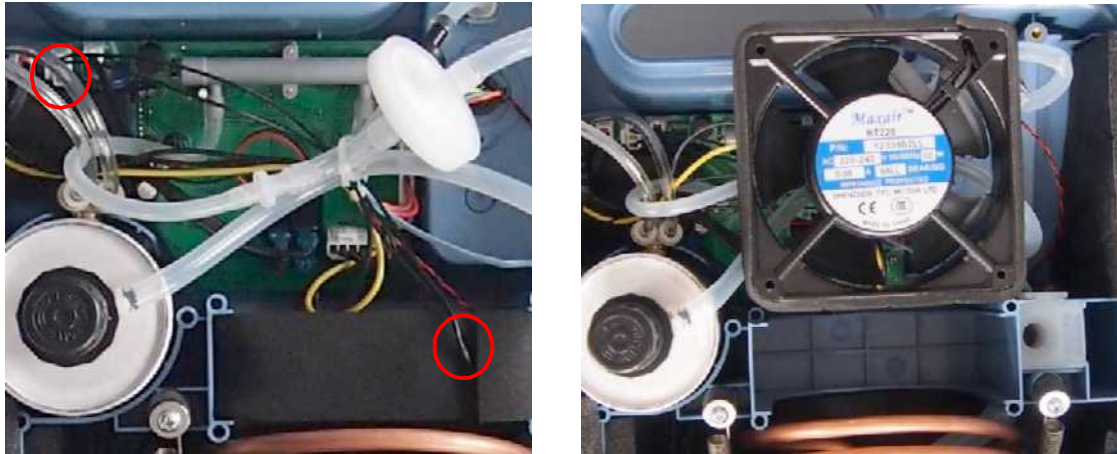

6.8 Circuit board replacement

The circuit board controls the main parts, such as power, valves, sensor and alarm system functions etc. Consult the troubleshooting chart in Part VII to determine when to replace the printed circuit board.

CAUTION: The circuit board contains components that are sensitive to electrostatic discharge (ESD) that can damage the board if not handled properly. As when handling any ESD sensitive board, observe standard ESD safety procedures. These procedures include the following:

- Handle the circuit board by the edges only
- Work on a grounded ESD mat
- Wear a grounded wrist strap
- Only store circuit boards in anti-static bags

6.8.1 Circuit board Removal

- (1) Turn off the power, and unplug the power cord.
- (2) Remove the back cabinet.
- (3) Cut the cable tie, and pull aside all tubes around the circuit board. Pull out the two tubes which connect the OSD on the circuit board. Disconnect all the leads and connectors on the circuit board. Lift the side of sieve beds which is close to the circuit board.
- (4) Remove the three screws which attach to the circuit board. Lift the board to remove.

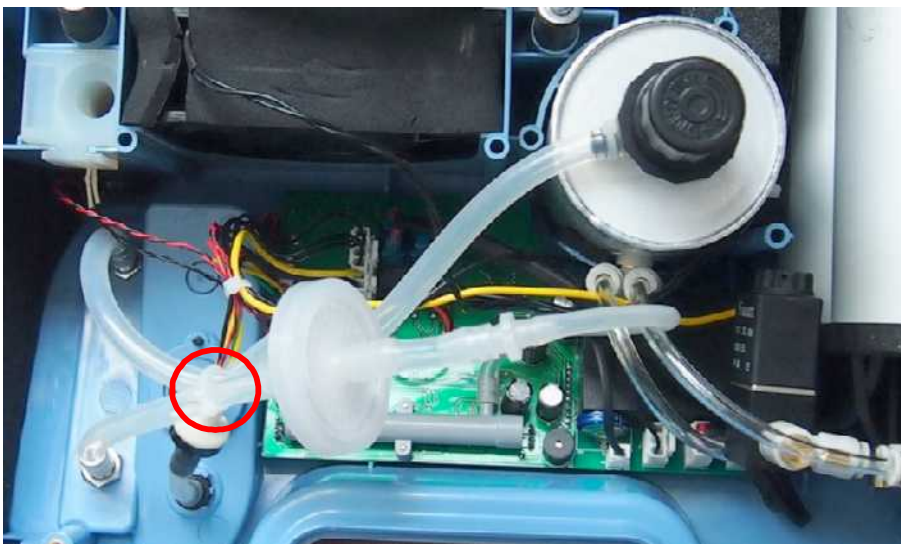
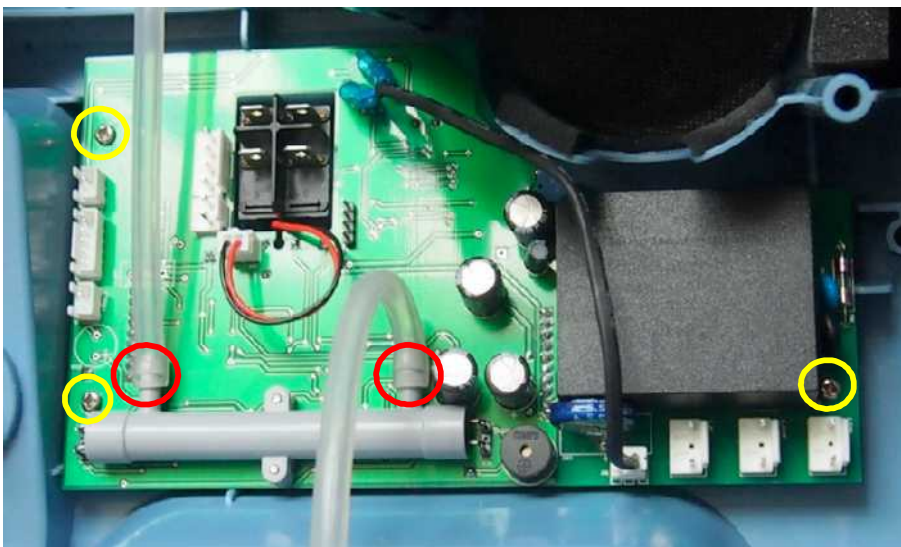

6.8.2 Circuit Board Installation

To install the circuit board, follow its removal procedure in reverse order. Align the screw holes of the circuit board, lay down the circuit board, and install the screws. Connect all tubes, leads, connectors to the circuit board as they were before.

NOTE: Handle the new circuit board only by the edges to prevent electrostatic damage to the unit. Remember the place of each tube, leads and connectors to install correctly.

6.9 LCD replacement

Side A

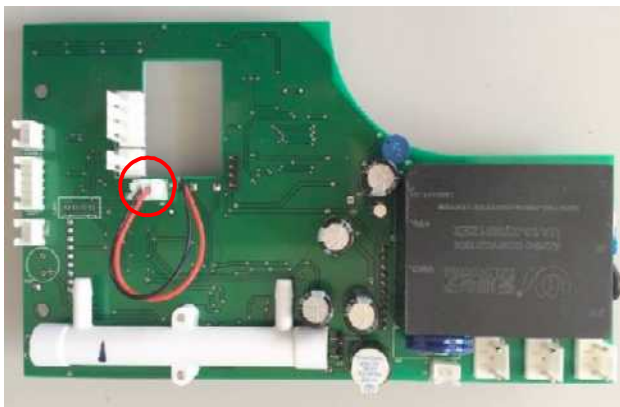

Side B

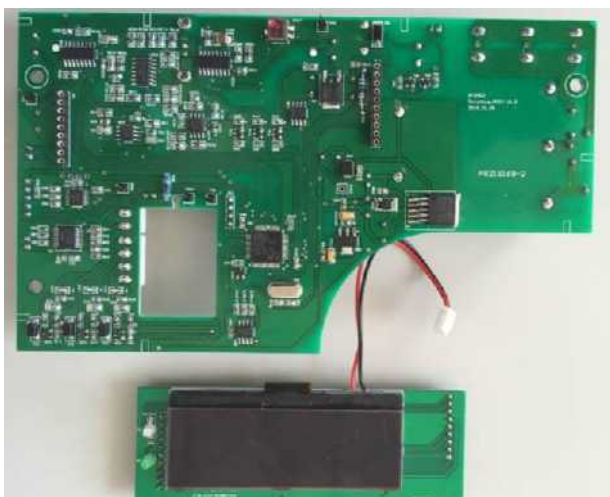
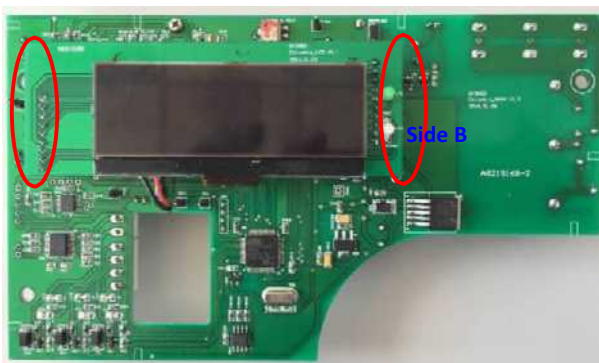

To replace the LCD, take the following steps:

- (1) Turn off the power and unplug the power cord
- (2) Remove the back cabinet
- (3) Pull aside the tubes, disconnect the leads on the circuit board. (Refer 6.8.1)
- (4) Take out the circuit board, remove the LCD leads from its socket on the circuit board, and remove contact pin of the LCD from the board. Then take off the LCD
- (5) Follow the removal procedure in reverse order to install a new LCD

6.10 Pressure regulating valve replacement

6.10.1 Pressure regulating valve replacement

If the flow meter ball fluctuates, or there is low oxygen purity, the pressure regulating valve may need to be checked, adjusted, or replaced. To replace the pressure regulating valve in the OxyFlow 5 unit, take the following steps:

- (1) Turn off the power, and unplug the power cord
- (2) Remove the back cabinet
- (3) Pull out the outlet tube, hold the pressure regulating valve tight, and turn anti-clockwise to remove it
- (4) Follow the removal procedure in reverse order to install a new pressure regulating valve

Note: When install the pressure regulating valve, apply an adhesive on the thread, and the tube which connect the outlet should be tightened with cable tie.

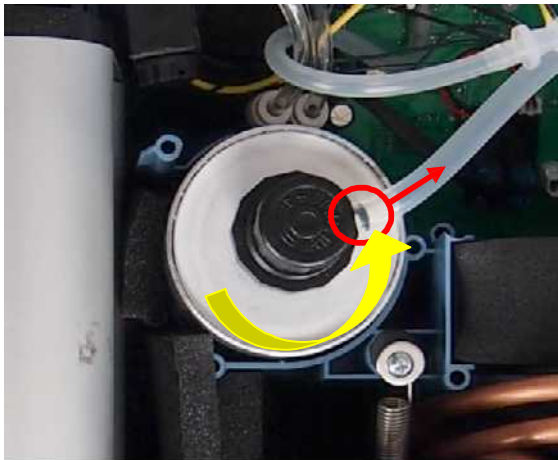

6.11 Power switch replacement

- (1) Turn off the power, and unplug the power cord
- (2) Remove the back cabinet
- (3) Remove the connector on the circuit board. Push forward to disconnect the power switch with the cabinet
- (4) When pulling out the wire on the circuit board. Be careful to note the color and position of each specific wire
- (5) Follow the removal procedure in reverse order to install a new power switch

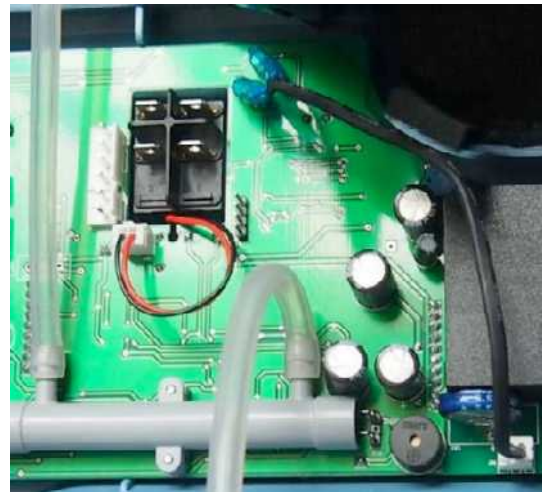
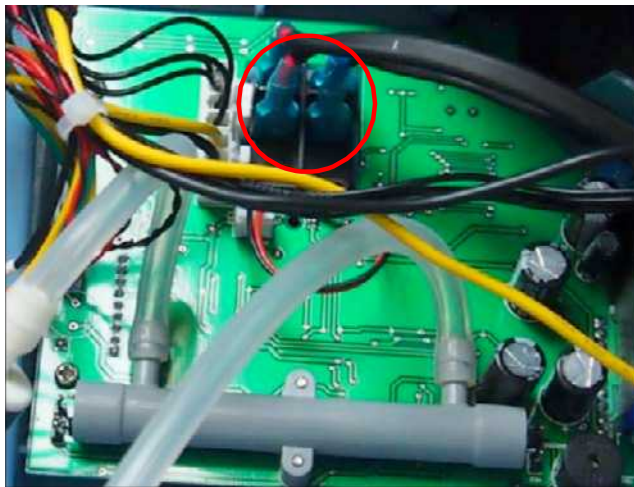

6.12 Flow meter replacement

6.12.1 Flow Meter Removal

- (1) Turn off the power, and unplug the power cord
- (2) Remove the back cabinet
- (3) Remove the tubes from the flow meter fittings
- (4) Unscrew the flow meter nuts with a wrench
- (5) Remove the flow meter from the cabinet



6.12.2 Flow Meter Installation

To install a new flow meter, follow the flow meter removal procedure in reverse order. Then perform a leak test on the connections.

Part VII Troubleshooting

7.1 The machine working pressure test

Testing the OxyFlow 5 operating pressure can help diagnose component failure in the PSA system.

Test procedure:

- Disconnect power to the concentrator.
- Open the concentrator cabinet.
- Using the pressure test kit and with power disconnected from the machine, remove the compressor air feed tube from the valve assembly and attach the gauge as shown in the picture.
- Turn the concentrator on and set the flowmeter to 5LPM.
- Let the OxyFlow run for five minutes.
- Make sure there are no leaks at the connections to the kit.
- Observe the maximum and minimum readings on the pressure gauge.
- Maximum reading should be no more than 35psi.
- Minimum reading should be no less than 10psi.

7.1.2 High Operating Pressure

Higher than normal operating pressure may indicate:

- Malfunction of the PSA cycle due to a bad valve or circuit board.
- Clogged exhaust muffler.
- Kinked tubing.
- Bad Sieve Beds.



7.1.3 Low Operating Pressure

Lower than normal operating pressure may indicate:

- Clogged intake filter.
- Malfunction of the PSA cycle due to a bad valve or circuit board.
- A leak in the unit.
- Low compressor output.

NOTE: When you turn the unit on, it can take several minutes to reach normal operating pressures

7.2 General Troubleshooting

Before reviewing the troubleshooting chart, the following steps may be useful to analyze any malfunctions:

- (1) Turn the concentrator on. If unit does not operate, refer to troubleshooting chart.
- (2) Make sure all filters are clean.
- (3) Make sure that the unit is leak free by testing all tubing connections and fittings. Protect circuit board from the solution and start a leak test at the compressor outlet, following the air flow through the unit to the oxygen outlet. Repair all leaks by tightening connections and fittings.
- (4) Review troubleshooting chart to analyze and repair any other malfunctions.

7.3 Troubleshooting table

PROBLEM	PROBABLE CAUSE	SOLUTION
There is no alarm when the machine is not receiving power	Defective circuit board The machine has not been used for a long time affecting the capacitor	Replace circuit board Connect power and run the machine for a while to let the capacitor charge
Compressor safety valve exhaust is triggered	Defective pneumatic valve Defective circuit board Defective safety valve	Replace pneumatic valve. Replace circuit board. Replace safety valve.
Circuit board works, but pneumatic valve is not switching normally.	Pneumatic valve wear and tear or too much dust in the valve	Replace pneumatic valve.
The oxygen purity is normal but the LCD screen is displaying the low concentration alarm.	The oxygen sensor device on the circuit board is defective	Replace circuit board
Compressor does not start or is slow; Compressor works with loud sound	Bad power connection point, defective capacitor or defective compressor; The compressor getting wear and tear due to long time use, or compressor parts such as bearing, rubber cup are damaged	Check whether the power cord is plugged in well. Replace capacitor, Replace compressor.
The machine shakes obviously	Compressor damper springs are damaged or the spring mount has screws loose.	Check whether the damper springs and screws are dislocated. Relocate and fasten the springs and screws.
The equipment works well, but the oxygen concentration is low.	Pressure equalizing valve is damaged	Replace Pressure equalizing valve or tightened the regulator
The equipment works well, but there is no oxygen output or oxygen concentration is low, and flow meter fluctuates.	Pressure regulator valve damage. Defective flow meter.	Replace regulator valve. Replace flow meter.
There's no or only partial LCD display	Defective LCD	Replace LCD
High Pressure Alarm The malfunction code is H:07	Defective sieve beds	Replace sieve beds
Low Pressure Alarm The malfunction code is H:06	Oxygen outlet tube damage, pressure regulator valve broken or the flow is set too high causing low pressure	Replace tube, pressure regulator valve. Adjust flow meter and the flow should not exceed 5 lpm. Replace circuit board
High Temperature Alarm The malfunction code is H:02	Defective radiator or fan exhaust outlet blocked Defective circuit board	Replace radiator or fan. Clear blockage Replace circuit board
The fault of OSD Sensor circuit, the malfunction code is E:03,	Defective OSD Sensor	Replace circuit board
Low oxygen concentration alarm. The malfunction code is H:04,	See chart below for low oxygen concentration analysis	

Flow Chart for Low Oxygen Purity Analysis

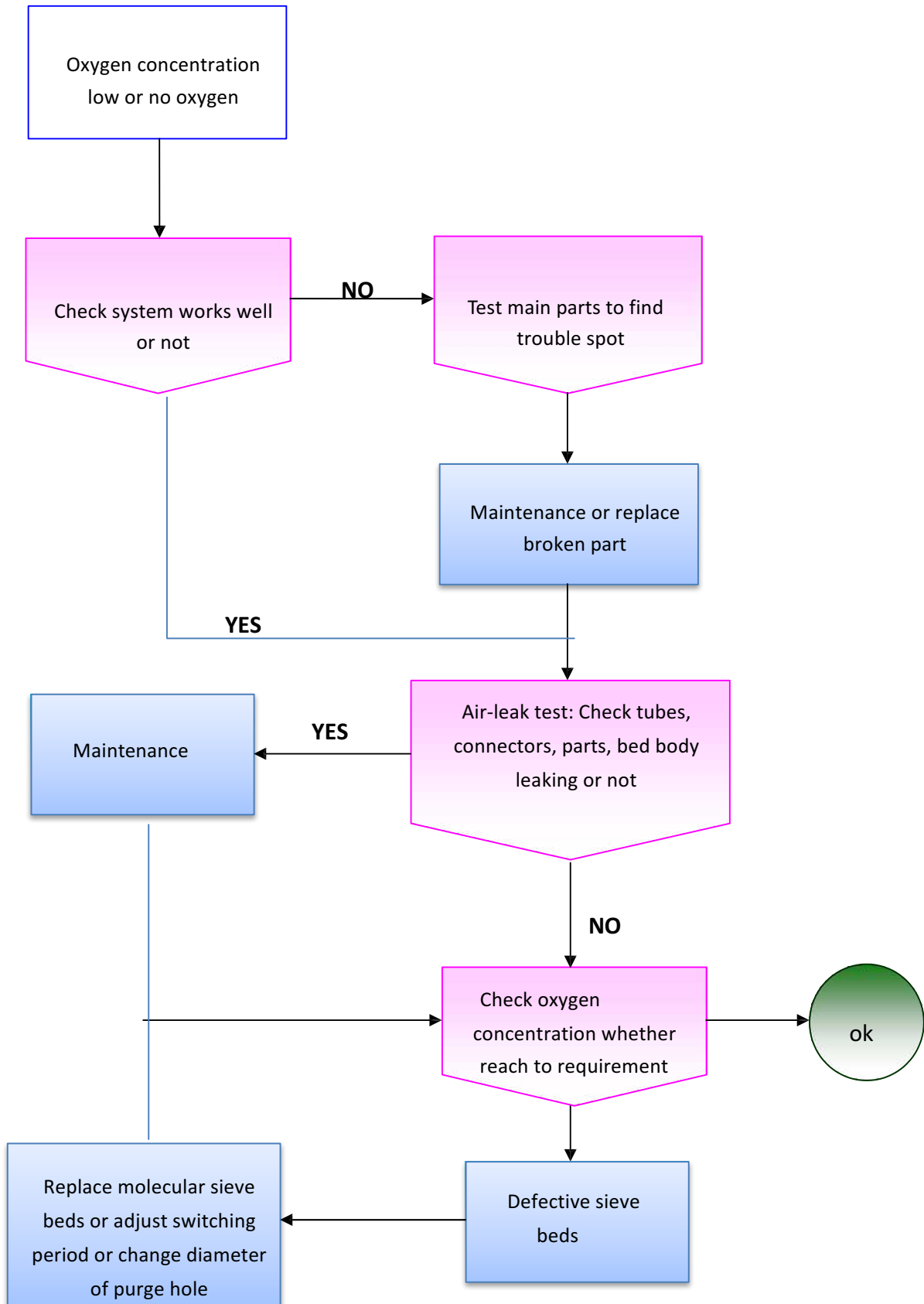

7.4 Tools table

The tools needed for you to properly service the OxyFlow 5 unit are listed below:

NOTE: An accurate pressure test gauge to take pressure readings on the unit should be kept available at all times.

Table 3 Main Tools & Accessory Materials

TOOLS		MATERIALS	
NAME	MODEL	NAME	MODEL
"+" Screw driver	300mm ~ 250mm	Insulating tape	
"-" Screw driver	200mm	Adhesive	704
Diagonal pliers		Sealing strip	
Solid wrench	8 ~ 10	Cable tie	2.5×100mm
Solid wrench	12 ~ 14		
Solid wrench	13 ~ 15		
Multimeter			
Pressure gauge	0 – 50 psi		
Oxygen concentration analyzer			
Tube cutter			

Attachment I Circuit Diagram

OXYFLOW 5

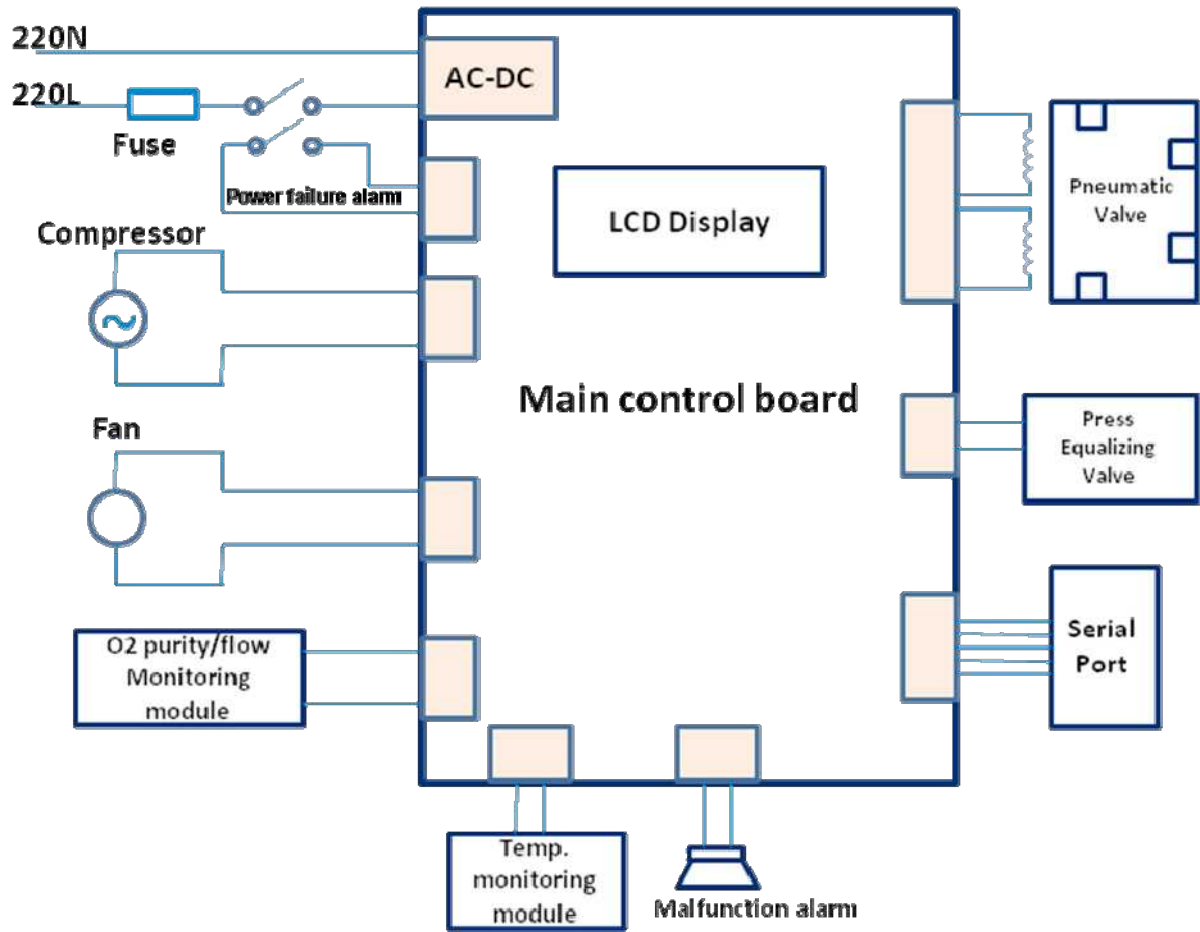

QUALITY WARRANTY

Model	Warranty Period
OXYFLOW 5	3 years

All after-sale service commitment shall be fulfilled by the supplier, dealer or the appointed maintenance company.

During the warranty period, if the product fails under conditions of normal use, the damages to the equipment are not caused by man-made reasons, the supplier, dealer or the appointed maintenance company is responsible for the maintenance or replacement free of charge.

The warranty does not include consumables like oxygen tubing, filters etc. The warranty does not cover the breakdown or damages caused by improper operation, abuse of the product, accident, or to products damaged because of repairs made to any components without the specific consent of the supplier. The users should not dismantle the equipment by themselves in the warranty period.

This warranty does not include normal wear and tear or shipping charges. Sanrai International, the dealer's sole obligation, and your exclusive remedy under this warranty shall be limited to such repair or replacement. Sanrai International shall not be liable for any consequential or incidental damages whatsoever.

After the warranty period, or damages excluded in the warranty, the supplier, dealer or the appointed maintenance company will charge the customers for any repairs made.